

Module and Application Description

Supplement for Applications with Redundant Design

Publication No.
D KWL 6332 94 E, Edition 06/94

PROCONTROL P

Analog Control

Control Module

for Analog Control Function with Continuous Output, 1- and 2-fold

83SR07 – E/R1210

Application

This module can be used to implement input and processing module redundancy in the PROCONTROL system. As a supplement to the updated module description for the module 83SR07–E/R1210, this document focusses on the module's redundancy-related features.

Features

Processing is performed in parallel in the on-line and standby units. When a redundancy switchover is effected, this results in a bumpless transfer of the processing functions to the standby unit. This bumpless changeover is ensured by synchronizing the standby unit with the on-line unit by means of synchronizing telegrams.

Both on-line and standby units are self-monitoring. Any disturbances within the modules are signalled to the appropriate redundancy control module 88TR01 via the SSG line.

All process connections (connectors X21) of the individual modules belonging to a redundant pair are connected in parallel by appropriate wiring in the station.

The input resistors (burdens) are connected in the on-line unit and disconnected in the standby unit. This is also true for the process outputs and for the transducer and contact supplies from the module.

For diagnostic purposes, standby units transmit a sign-of-life telegram on the bus.

Addressing

Sign-of-life telegram

On-line units transmit all telegrams as structured in the address list. Standby units transmit a sign-of-life telegram for diagnostic purposes. This is always register 0. If register 0 has been structured in the address list, the process telegram is transmitted with the appropriate data type. If register 0 has not been structured, a default telegram with data type 0 is transmitted. The sign-of-life telegram is transmitted cyclically.

Diagnosis

The module's hardware and software functions are monitored. The signalling and monitoring concept is shown in Fig. 1.

All annunciations are signalled via the SST line and indicated by the ST lamp on the module's front panel.

When a module's SSG line is activated, this is interpreted as a module disturbance by the redundancy control module 88TR01 and indicated by the SG lamp on the module's front panel.

Operating states of the module

Structure, address, parameter and limit value lists

For redundant operation, all of the lists contained in the modules (structure, address, parameter and limit value lists) must be identical in the two redundant units. This can be ensured by the user with the aid of the PDDS.

Simulation

When simulating redundant operation, the module signals simulated for the two redundant units must be identical. This is ensured by the PDDS.

Checksum

A checksum for all active lists (structure, address, parameter and limit value lists) in the EEPROM or RAM as well as the module firmware is formed in the module. This checksum can be used to verify that the contents of the lists in the on-line and the standby units are identical. The checksums can be displayed by the PDDS.



Module configuration

Redundant operation

No special configuration is needed for redundant operation. However, the structuring of the two redundant units must always be identical. This must be ensured using the PDDS.

Plug-in jumpers

The user has to make sure that the jumper settings (X200, X201, X202, X203) are identical in the on-line and the standby unit.

Function blocks

Synchronism

Function blocks with memory functions are synchronized by means of synchronizing telegrams transmitted from the on-line unit to the standby unit. The contents of the telegrams depends on the function block concerned. In the event mode, synchronizing telegrams are transmitted whenever a change occurs. All synchronizing telegrams are single-destination telegrams with data type 27. They do not have to be configured.

The synchronizing telegrams are also transmitted cyclically (in each remote bus cycle, all synchronizing telegrams of one station are transmitted) in the background for the purpose of monitoring the transmission path of the synchronizing function. If the monitor is activated, this is indicated by the annunciation "synchro-monitoring responded".

Synchronization after module restart following connection of supply voltage, insertion of the module, or reloading of user lists

After each restart, the on-line module is put in an operational state and immediately starts performing its processing functions and transmitting synchronizing telegrams to the standby unit.

When a standby unit is restarted, it is put in an operational state. The unit's disturbance lamp ST will light and the annunciation "synchro-monitoring responded" will be present in the diagnostic register until the unit has received the required synchronizing telegrams. When all synchronizing telegrams have been received, this means that the processing statuses of the on-line and standby units are identical.

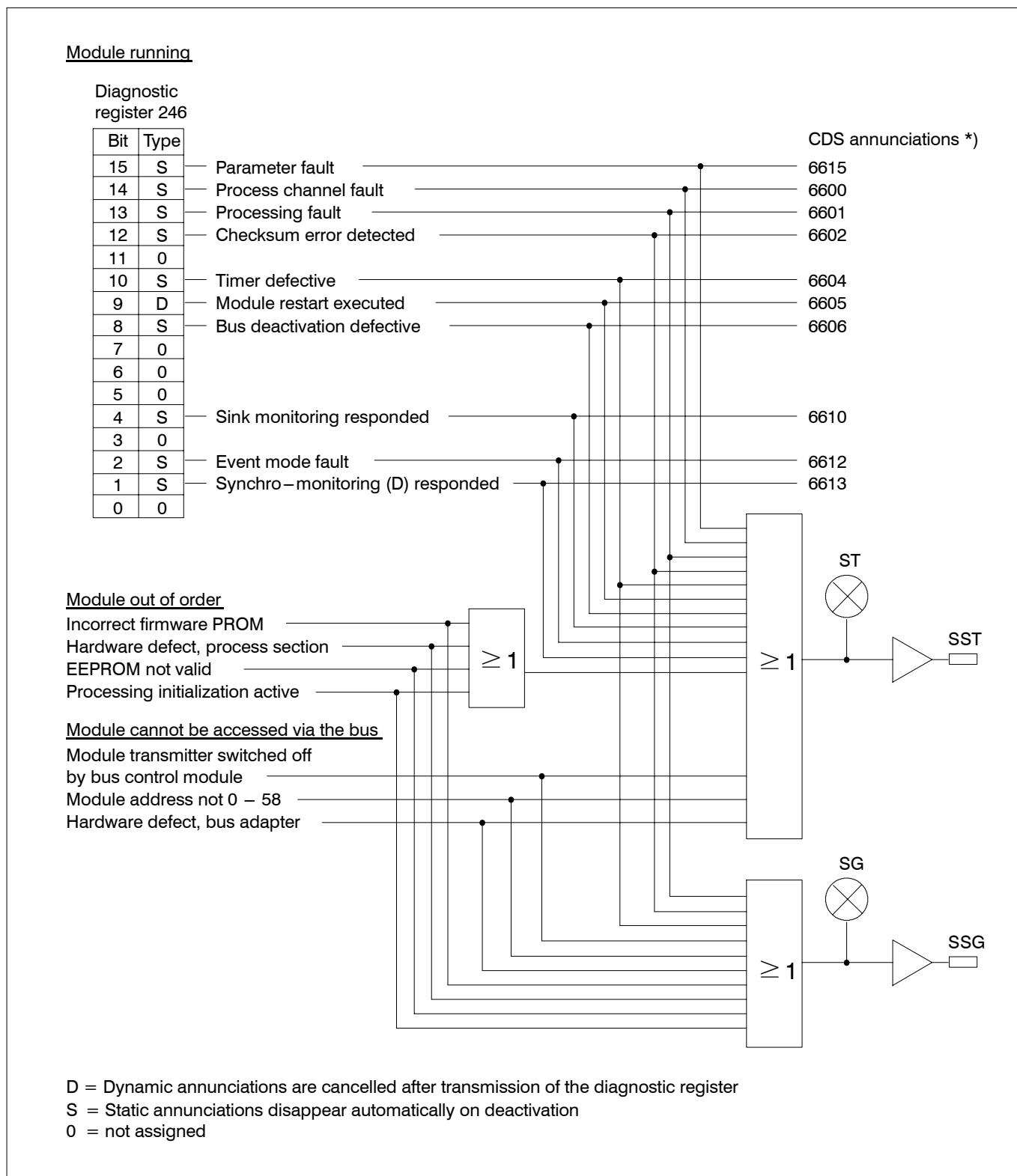

Figure 1: Diagnostic signals of 83SR07

- *) The control diagnostic system (CDS) provides a description for each annunciation number. The description includes:
- Explanation of the cause and effect of the disturbance
 - Recommendations for correction.

This makes for fast elimination of disturbances.

Function diagram

Connection designations

The printed circuit board is provided with the connectors X11 and X21.

Connector X21 includes all process inputs and outputs. Connector X11 includes the station bus connection and the operating voltages USA and USB.

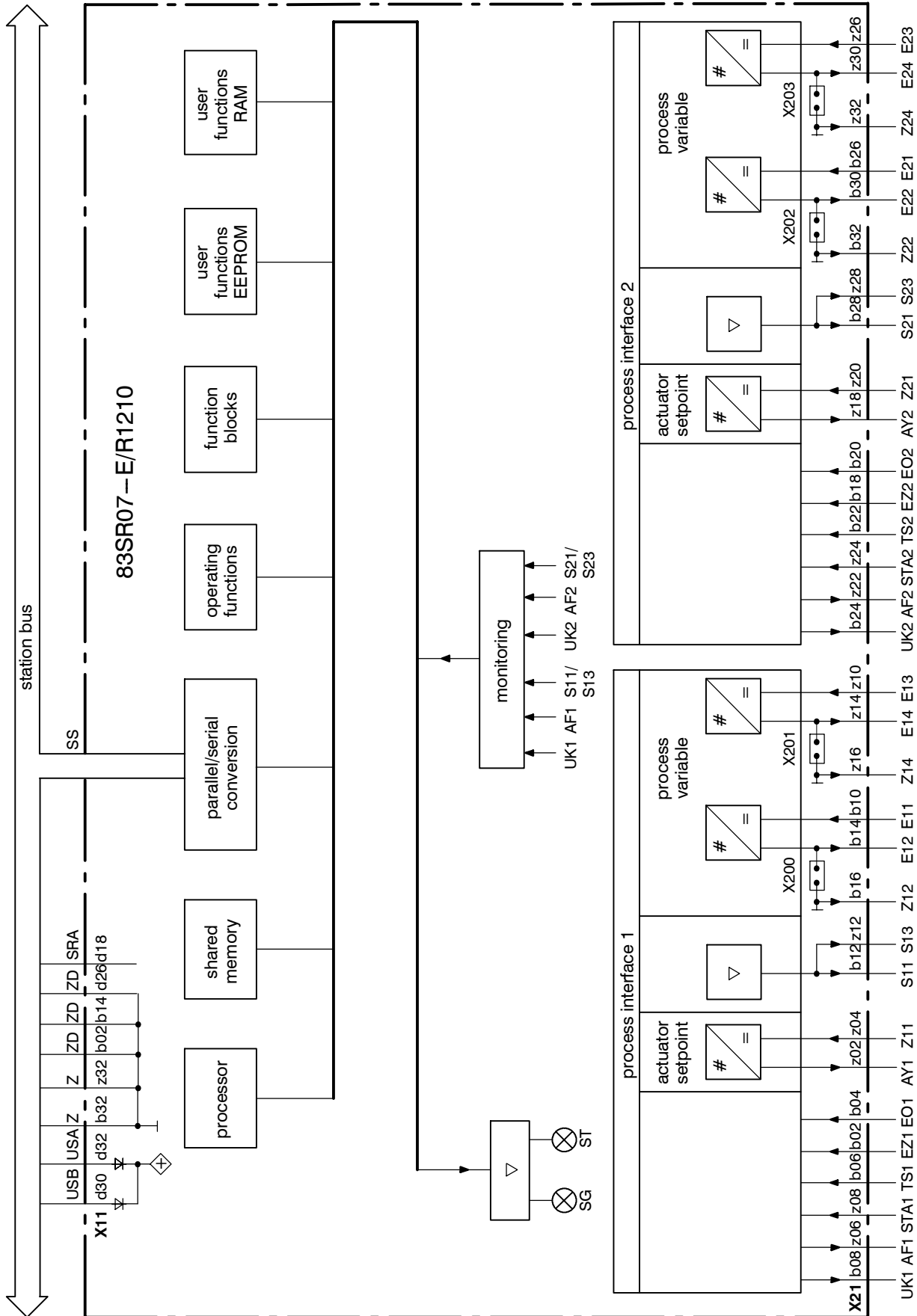

Basic connection diagram

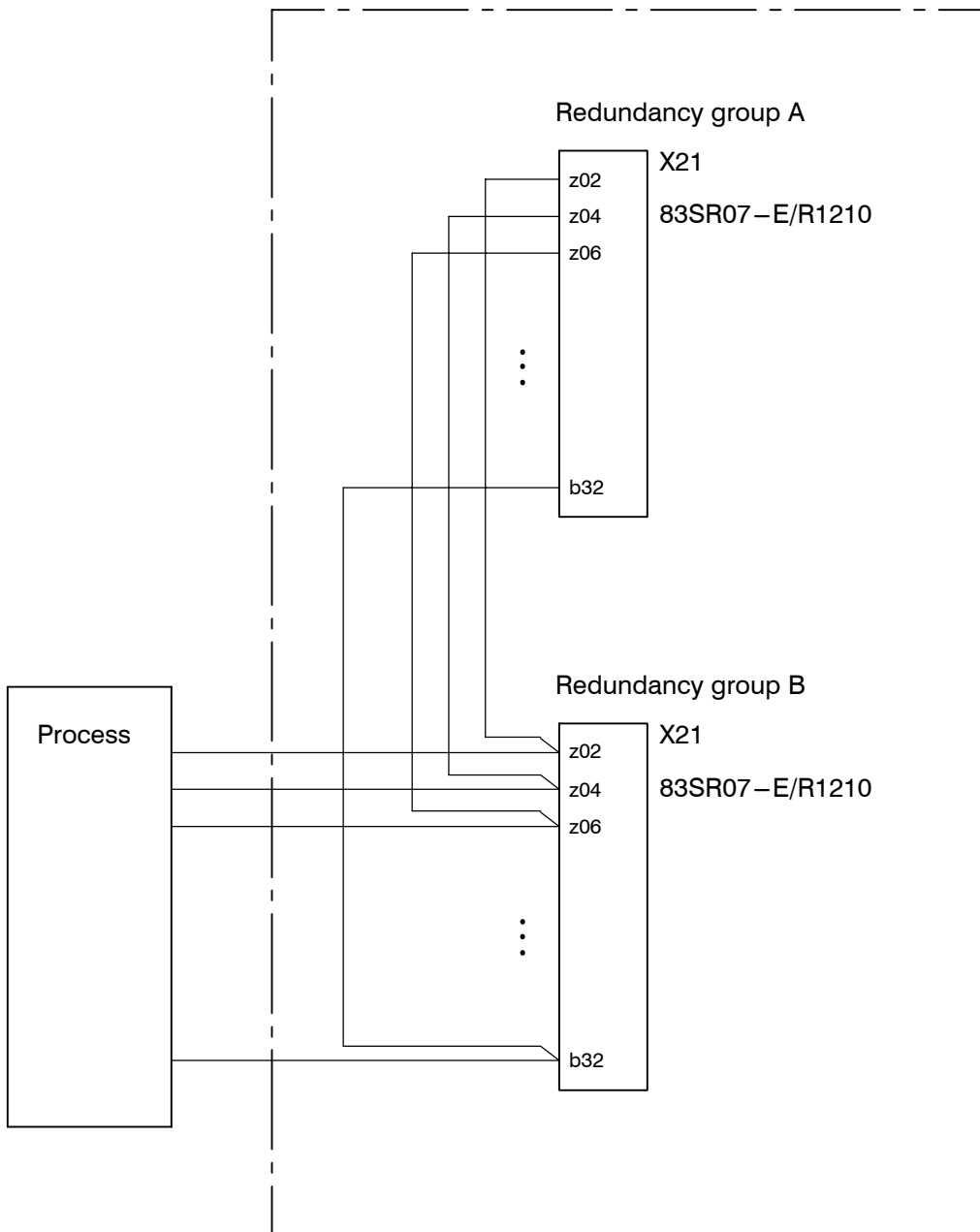

Connection diagram

83SR07-E/R1210

Module in standby mode
e. g. process interface 1

from / to the process

Module in on-line mode
e. g. process interface 1

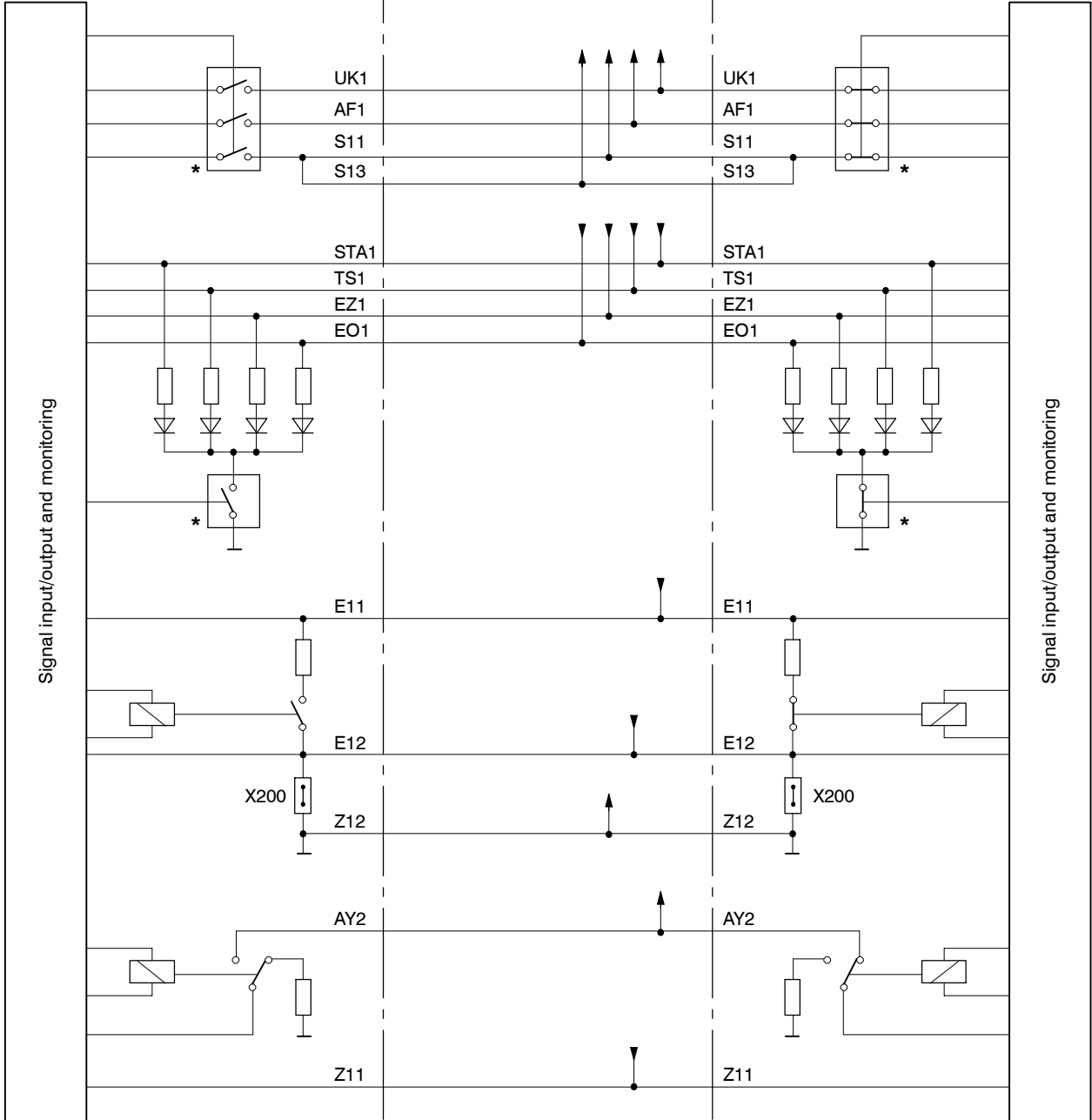

* electronic switch

Technical data

Power dissipation

On-line status

$P_v = 5 \dots 8.4 \text{ W}$

Standby status

$P_v = 2.3 \dots 3.5 \text{ W}$

depending on operating voltage and configuration

Redundancy switchover

Enable time for process outputs

$\leq 10 \text{ ms}$

Disable time for process outputs

$\leq 10 \text{ ms}$

Technical data subject to change without notice!



ABB AG
Power Technology Systems

P.O. Box 10 03 51
68128 Mannheim
Germany

Phone: +49 (0) 621 381 –3000
Fax: +49 (0) 621 381 –2645
E-Mail: powertech@de.abb.com
Internet: <http://www.abb.de/pt>

NOTE:

We reserve the right to make technical changes or modify the contents of this manual without prior notice. With regard to purchase orders, the agreed particulars shall prevail. ABB does not accept any responsibility whatsoever for potential errors or possible lack of information in this document..

We reserve all rights in this document and in the subject matter and illustrations contained therein. Any reproduction – in whole or in parts – is forbidden without ABB's prior written consent.

Copyright© 2005 ABB All rights reserved