



Symphony Plus SD Series: HPC800 controller

Symphony Plus

SD Series: HPC800 controller

Symphony® Plus is the new generation of ABB's widely acclaimed Symphony family of distributed control systems – the world's most widely used DCS in the power generation and water industries. In all, there are more than 6,500 Symphony DCS installations in operation all over the world, more than 4,500 of which are in power and water applications.

1 SD Series HPC800 controller



No other automation platform has such a long field record and large installed base in power and water applications as Symphony. For more than 30 years, ABB has evolved this family, ensuring that each new generation enhances its predecessors and is backwardly compatible with them - all in accordance with ABB's long-held policy of 'Evolution without obsolescence.'

Included in Symphony Plus is a comprehensive suite of standards-based control hardware and software that meets the requirements of total plant automation. SD Series HPC800 represents the newest addition to the S+ Control family. HPC800 control-based system solutions feature modular DIN-rail packaging; a flexible, high-performance Fast Ethernet-based plant network; intelligent electrical and field device integration; PROFIBUS and HART communication protocols; integrated turbine control; an efficient, easy-to-use engineering tool, and a state-of-the-art HMI workplace.

Together, HPC800's technology enhancements meet the present and future needs of the power generation and water industries. HPC800 control-based solutions lower system installation and maintenance costs through their smaller footprint, reduced field wiring, simplified and repeatable engineering, shorter project schedules, tighter and more reliable process control, and greater visibility of plant operations to all users of plant data.

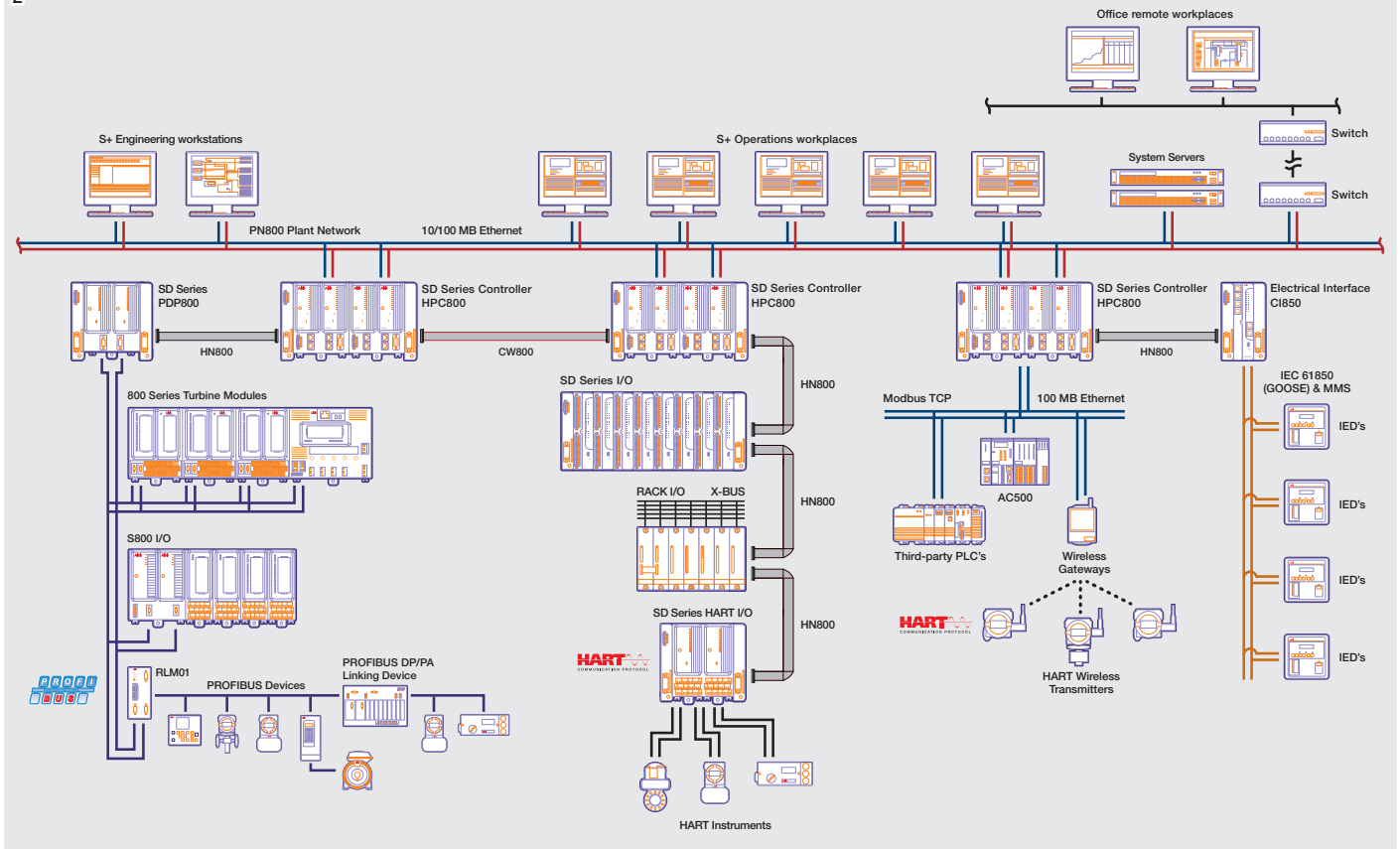

2 Functional overview of HPC800 capabilities

Overview

The SD Series HPC800 controller is a high-performance, high-capacity process controller that is used to support the plant's total control requirements, from discrete and continuous, to batch and advanced control applications.

The HPC800's controller environment executes demanding process control applications that are both data and program intensive. Redundancy options are available at all levels of control, I/O and communication, resulting in maximum flexibility and availability.

Along with a range of I/O options, the HPC800 delivers powerful, versatile and scalable automation solutions for plant applications of all sizes.

Simultaneously, the HPC800 connects to DIN style I/O modules and traditional Rack I/O modules. Intelligent I/O devices such as smart transmitters, actuators, intelligent electronic devices (IEDs), and third-party PLCs are easily integrated through industry-standard fieldbuses and networks. Each device's resident information can be used in control strategies and higher-level applications in order to produce tighter and more reliable process control solutions.

The HPC800 controller uses ABB's extensive set of field-proven standard function code algorithms and S+ Engineering's graphical design tools to develop its control strategies. By using the same function code algorithms as previous generation Harmony and INFI 90 rack controllers, the HPC800 supports the easy and risk-free re-use of time-tested, field proven control application solutions.

All in all, the HPC800 provides users with the benefits of fast, accurate and uninterrupted control of their process.

S+ Operations, S+ Engineering and other applications communicate with HPC800 controllers over the system's high-speed, high-throughput and high-security 100 Mbps Fast Ethernet-based redundant communication Plant Network (PN800). The network-centric architecture allows for integration of field devices, process and electrical system areas, and business enterprise systems in a simple, scalable, seamless and secure manner.

The HPC800's functional capabilities are summarized in figure 2.

Protecting the integrity and confidentiality of system data

The process and power industries face intensifying cyber security risks. In order to increase stability, security and robustness in its solutions, ABB has established an independent Device Security Assurance Center (DSAC) where cyber security robustness is tested as part of the product development process. The DSAC test facility uses state-of-the-art open source, commercial and proprietary robustness and vulnerability analysis tools in its certification testing. All Symphony Plus Ethernet-based devices - including SD Series products such as the HPC800, and CI850 - are continually tested at the DSAC center in different configurations and with an explicit focus on operational performance. This ensures that all Symphony Plus products are robust, secure and of the highest quality.

Symphony Plus

SD Series: HPC800 controller

Powerful process controller

The HPC800 is the latest in a long line of field-proven process controllers. Based on a 256 MHz, 32-bit Freescale Coldfire processor, the HPC800 controller can be adapted to a broad spectrum of applications and process requirements. Configured by S+ Engineering tool, the HPC800 features an extensive library of more than 150 pre-defined control algorithms or function codes (figure 3). These functions provide the ability to easily design complex control strategies to fit any control application, including continuous, sequential, batch and advanced control. In addition to standard function blocks, the HPC800 supports C programming, batch, and user defined function codes.

HPC800 controller features include:

- Simultaneous support for SD Series I/O, Harmony Rack I/O, and S800 I/O subsystems
- Execution of closed loop control of more than 5,000 I/O in less than 250 msec.
- Downloadable firmware
- Extended user configuration memory (NVRAM) and runtime memory (RAM)
- Support for 30,000 function blocks
- Flexible and online configuration capability
- Support for up to 8 segment tasks, each segment supporting execution cycle time down to 1 msec
- Dedicated redundant peer-to-peer controller communication bus supports update rates less than 100 msec

High reliability and availability

The HPC800 is designed to provide maximum reliability and availability. With a redundant design at all levels - CPU, power, internal bus, I/O networks, communication ports and plant network - HPC800 controller subsystems provide the highest level of availability. Compliance with international standards assures the highest level of reliability and quality needed to meet the most rigorous specifications and requirements from around the world. Together, they give users the benefit of fast, accurate, uninterrupted control of their process production, resulting in greater production efficiency, increased availability and lower maintenance costs.

Ease of use

HPC800 utilizes a DIN-rail form factor, standard 24 VDC power inputs, and a standard Ethernet network to make installation simple and flexible. This reduces the limits on cabinet space, size or layout, and provides a broader selection of commercial power supplies and network peripherals, thus lowering both installation and maintenance costs.

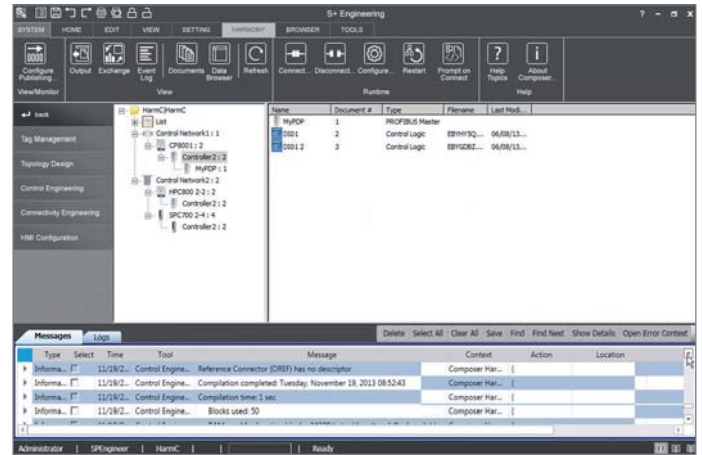

3 S+ Engineering

Peer-to-peer controller communications

HPC800's dedicated bus (CW800) for peer-to-peer controller communications can achieve update rates of less than 100 msec. It is essential for fast and accurate control, coordinating between several process segments (ie, between boiler and turbine), and for when a process point is used in several subsystems without adding a field transmitter or cable. The CW800 peer-to-peer communication bus is fully redundant.

Soft controller reduces commissioning times

For new plant, upgrade, or expansion projects, SD Series soft controllers can dramatically reduce commissioning and start-up time and costs by permitting thorough testing and pre-tuning of control loops prior to its implementation in the field. The SD Series soft controller uses the same control logic (ie, function block configuration) as the physical SD Series controllers. Coupled with virtual communication devices, the entire SD Series control-based system can be implemented within one or more PCs which allow for testing results made in the virtual environment to be directly transferable to the operating system environment.



4 SD Series I/O | 5 SD Series HART I/O: HAI805 and HAO805

Comprehensive I/O support

The HPC800 provides simultaneous support for SD Series I/O, Harmony Rack I/O and S800 I/O subsystems, and is capable of providing closed loop control for 5,000 I/O points in less than 250 msec. This provides great flexibility and a wide variety of input/output and signal condition capabilities, which in combination form the optimal automation solution. Using standard function codes, the S+ Engineering Composer tool is used to configure and maintain all HPC800 I/O modules and channels.

Through a redundant I/O network, HN800, each HPC800 controller can communicate with up to 64 SD Series I/O modules, SD Series PDP800 PROFIBUS modules, or Harmony Rack RIO22 modules. Each PDP800 can drive more than 1,500 S800 I/O modules over PROFIBUS DP V2, while each RIO22 module can drive 64 Harmony Rack I/O modules. All HPC800 I/O can be configured as either local I/O or remote I/O or mixed. Remote I/O is communicated via a fiber optic extension. Sequence of events (SOE) with 1 msec timestamp resolution is available across the entire system.

In addition to traditional signal-type I/O, the HPC800 provides for integrated turbine control via a series of turbine control-specific modules. These are available in either Harmony Rack form or Symphony Plus DIN-rail form and include:

- Hydraulic Servo Module (HSS and VP800)
- Turbine Protection Module (TPS and TP800)
- Turbine Auto Synchronization Module (TAS and AS800)
- Condition Monitoring Module (CMM and MCM800)



Intelligent HART I/O

HPC800 controllers seamlessly integrate HART field devices through the HAI805 and HAO805 HART modules. This provides access to a wide range of intelligent field devices including transmitters and actuators from ABB and other vendors. Besides the 4-20 mA primary variable, all secondary, tertiary and quaternary variables in a HART device can be accessed by Function Code control applications in the HPC800 controller. Real time use of this data is practical because of the modules' individual HART modem per channel design. Data can be calculated, used as part of a control strategy, or for display and alarm purposes at the S+ Operations console.

HPC800 HART capabilities allow users to take full advantage of their HART instrumentation investments. Too often smart devices are under-utilized instruments because of the limitations of the I/O system to accept the device's information. With SD Series HART modules, incorporation of the secondary variables in control strategies can reduce the overall number of field devices and I/O channels required. Visibility of HART diagnostic data at the system level reduces maintenance costs through the proactive response to degrading performance of field devices before a failure occurs.

Symphony Plus

SD Series: HPC800 controller



6 Redundant SD Series PDP800 PROFIBUS interface modules | 7 Seamless electrical integration via IEC61850

Device integration capability

The HPC800 controller architecture seamlessly integrates intelligent field devices and protocols using PROFIBUS DP, HART, Modbus TCP, and IEC 61850. This provides access to a wide range of intelligent field devices from both ABB and other third party vendors including transmitters, actuators, motor control centers (MCC), flame scanners, IEDs, etc. Each device's resident information can then be used in control strategies and higher level applications. In addition to producing tighter and more reliable process control solutions, these solutions lower installation costs by reducing wiring and system footprint.

Details on SD Series integration devices

The optionally redundant PDP800 PROFIBUS interface supports:

- PROFIBUS DP V0, V1, V2
- PROFIBUS PA devices through DP/PA linking device
- 1 msec time stamping of devices by PROFIBUS DP V2
- Electric and fiber optic media for PROFIBUS DP link

The CI850 electrical integration interface supports control and supervision of MCCs, switchgear, transformers, excitation systems and protective relays via IEC61850. Its main features are:

- Data modeling according to IEC 61850-7-3 /4
- MMS client functionality according to IEC 61850-7-2
- GOOSE publisher and subscriber functionality
- Capability to send Single and Double Commands
- Capability to send Select Before Operate Commands
- Up to 20 IEDs connected to a single CI850

Accomplished via the controller's 100 Mbps Ethernet port, Modbus TCP device integration supports:

- Bi-directional communication up to 4,000 Modbus points
- High availability and fault tolerance in a redundant pair configuration
- Ability to operate as client, server or server/client (concurrently) on the Modbus TCP network
- Expanded number of concurrent connections

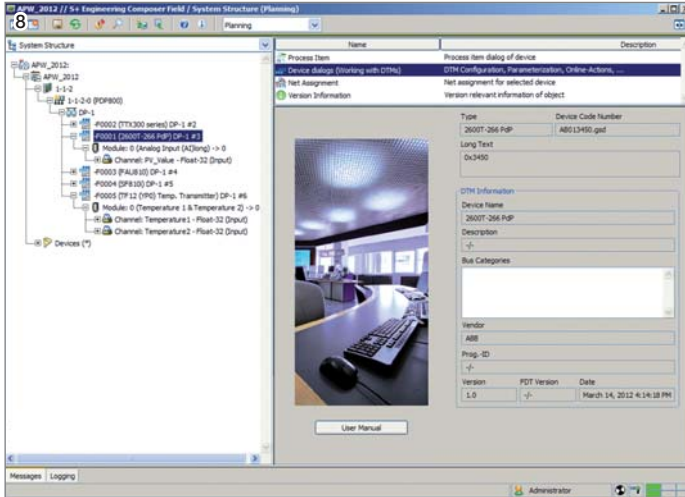

8 S+ Engineering Field Device Management tools | 9 INFI-Net to Ethernet bridge (IEB800)

Field device management

HART and PROFIBUS devices are fully integrated with Symphony Plus, yielding benefits far beyond reduced footprint and cable costs. The S+ Engineering tool suite supports configuration, commissioning and maintenance of HART and PROFIBUS devices using device type manager (DTM) technology. For field devices that have conventional device description files (GSD), a basic PROFIBUS DTM is available to allow standardized configuration. HART devices are integrated, configured and parameterized via standard HART protocol without the need for additional tools by using a standard HART DTM. The individual DTMs can be accessed from Composer Field's multiple data views, such as the system or location overview and others. Composer Field includes automatic net calculation and loading of process items by using the device-specific channel configuration generated from the DTM.

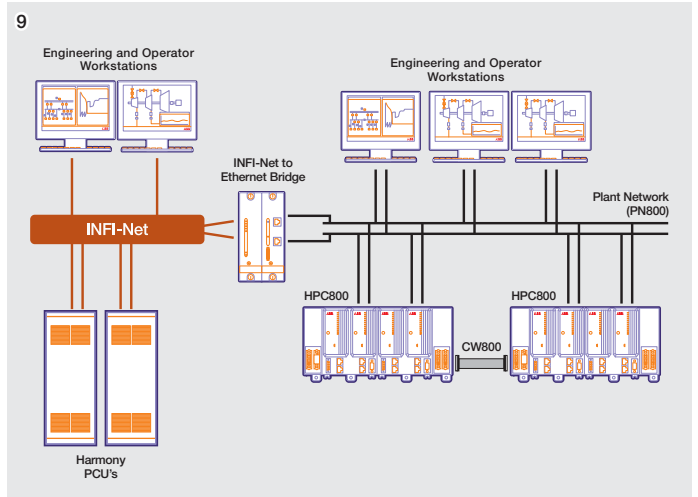

Based on field proven technology

The HPC800 controller uses ABB's set of best-in-class control technologies to build its automation solutions. This allows end customers and engineering, procurement and construction (EPC) contractors alike to effectively re-use their extensive library of ABB field-proven and time tested control solutions with these latest control products.

Specifically, HPC800 solutions:

- Use the extensive set of field-proven INFI 90 function code algorithms as previous generation controllers
- Use traditional INFI-Net exception reporting over redundant 100 Mbps Fast-Ethernet (PN800)
- Extend current Composer graphical design engineering tools with device management capabilities

Further, Symphony Plus Rack and DIN control networks, INFI-Net and PN800 respectively, can be connected via a self-configuring INFI-Net to Ethernet bridge (IEB800) module. Use of this bridge makes resident data on either network available for use in control applications or display in the other system (see figure 9).

Contact us

ABB Inc.

Power Generation

Wickliffe, Ohio, USA

Phone: +1 440 585 3087

Email: powergeneration@us.abb.com

ABB S.p.A.

Power Generation

Genoa, Italy

Phone: +39 01060731

Email: powergeneration@it.abb.com

ABB Pte. Ltd.

Power Generation

Singapore

Phone: +65 6776 5711

Email: powergeneration@sg.abb.com

ABB AG

Power Generation

Mannheim, Germany

Phone: +49 621 381 3000

Email: powergeneration@de.abb.com

www.abb.com/symphonyplus



© Copyright 2015 ABB

All rights reserved. Specifications subject to change without notice. Pictures, schematics, and other graphics contained herein are published for illustration purposes only and do not represent product configurations or functionality. User documentation accompanying the product is the exclusive source for functionality descriptions.

Symphony is a registered trademark of ABB S.p.A.